

# Leverandørkonferanse

Dynamisk Innkjøpsordning

19-SEP-2019

Ruter #

Hvordan skal våre innbyggere kunne bevege seg fritt og enkelt ...



# Sterk vekst for kollektiv, tar markedsandeler fra bil

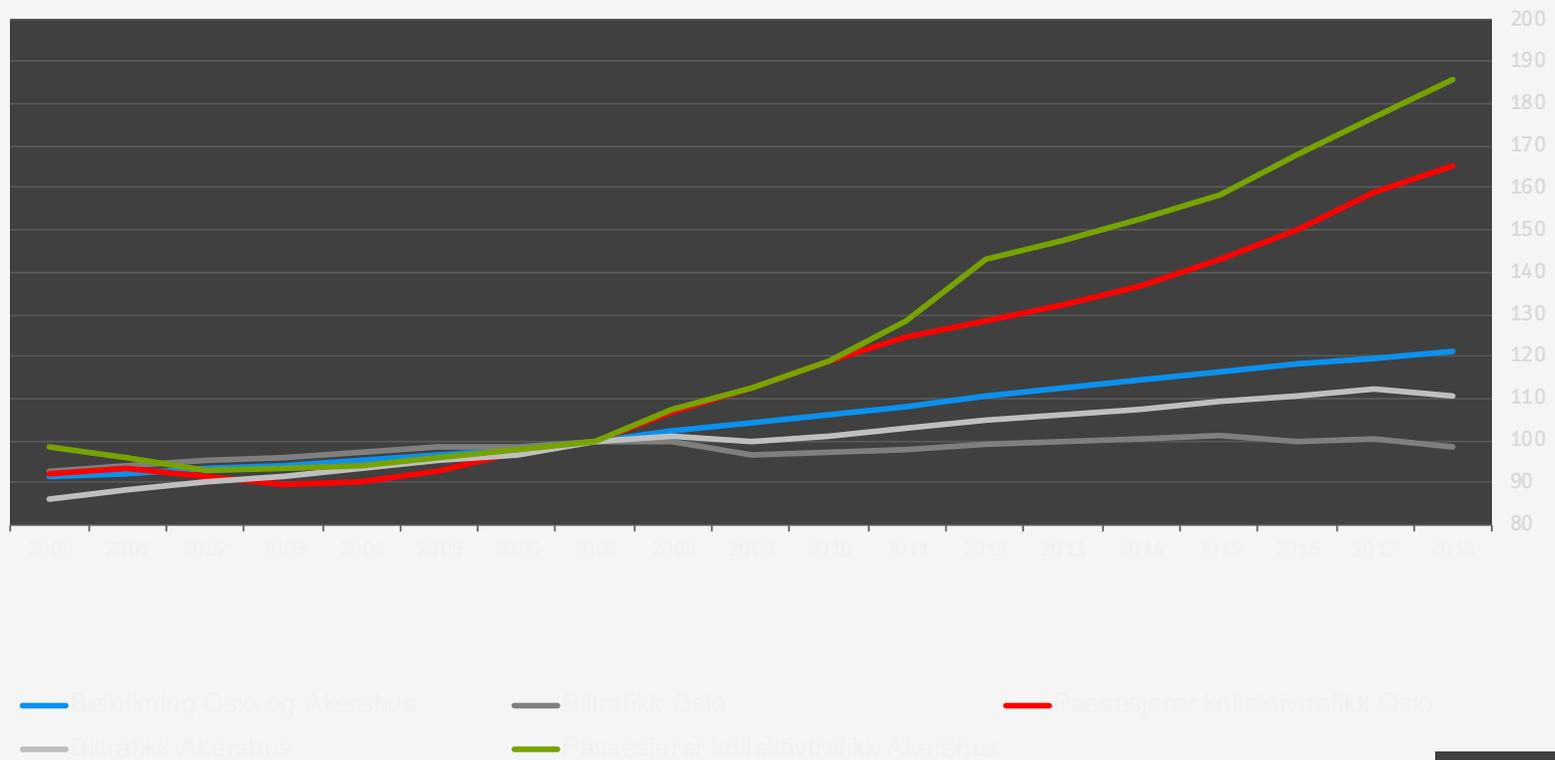



**Betydelig høyere vekst enn befolkningsveksten,  
som var 1,2% i Oslo og 1,7% i Akershus**

**Ruter#**

A photograph of two women sitting on a bus at night, laughing and talking. The woman on the left is wearing a light-colored coat with a fur collar and a headscarf. The woman on the right is wearing a dark coat and a plaid scarf. The bus interior is visible with yellow handrails. Outside the window, city lights and a street are visible at night.

**387 millioner** påstigninger **4,2%** vekst

Ruter #

# Samferdselssektoren står overfor store endringer

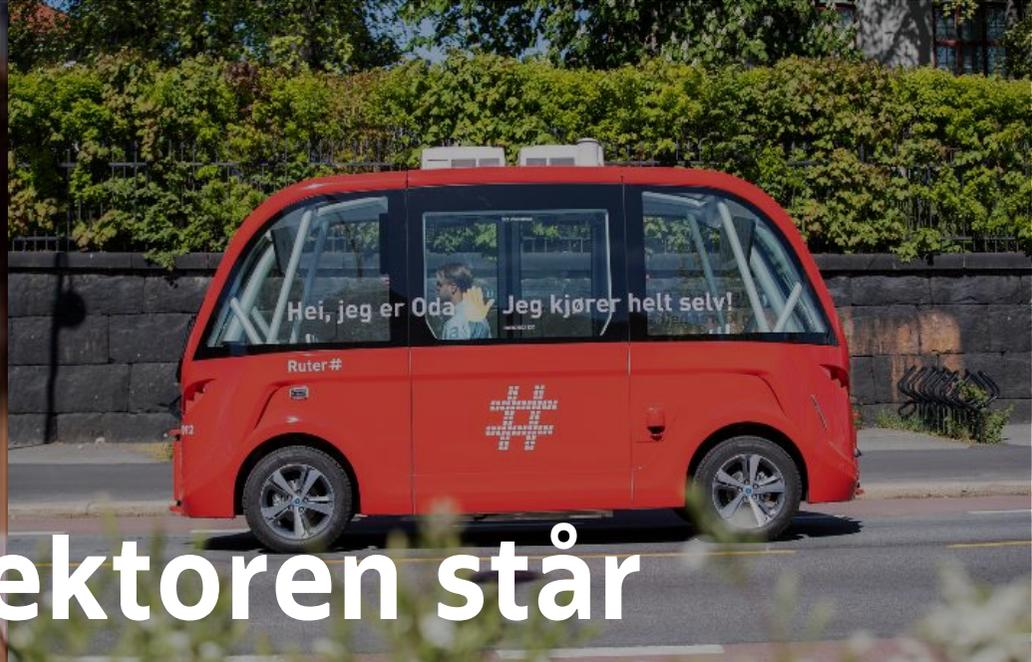
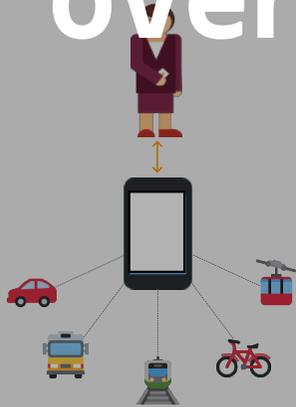

# Nøkkeldrivere for endring – fremtidens mobilitet

Elektrisk



Selvkjørende



Tilkoblet



Delt



# Vårt svar

## 1. Kundefokus



## 2. Bærekraftige løsninger



**Ruter#**



EFFEKT



HVORFOR



HVORDAN



Ruter#

Våre verdier:  
**Åpen, nytenkende, samhandlende og pålitelig**

Visjon

# Bærekraftig bevegelsesfrihet

Hovedmål



Tilby attraktiv  
mobilitet



Bidra til bærekraftige  
byer og samfunn



Fortjene tillit og  
oppslutning

Nøkkelresultater

- o Markedsandel kollektiv, sykkel, gange
- o Trafikkutvikling kollektiv
- o Tilfredshet med kollektivtilbudet
- o Trafikkutvikling nye mobilitetsformer
- o Utslippsfri 2028
- o Trafikksikkerhet
- o Sirkularitet
- o Sosial inkludering
- o Samkjøring
- o Omdømme i befolkningen
- o Omdømme hos samarbeidspartnere

**Ruter#**

... transformasjon ...

Ruter #

# Helhetlige mobilitetstjenester

Transport går fra:

- å være tilbudsrevet til **etterspørselsrevet**
- hyllevare til **skreddersøm** (gjennom digitalt grensesnitt)
- produkt til **tjeneste**



Danner grunnlag for sømløse, individuelt tilpassede mobilitetsløsninger

Og i praksis representere et reelt alternativ til å eie bil



For Ruter innebærer helhetlige mobilitetsløsninger:

## **Bevegelsesfrihet:**

- friheten til at innbyggerne i vår region kan leve sine liv ved å enkelt kunne reise dit en vil når en vil, og å kunne bo og jobbe der en ønsker

## **Bærekraft:**

- løsningene som tilbys skal være bærekraftige i den forstand at de ivaretar miljø-, sosiale og næringslivshensyn og at vi bidrar til mer bærekraftige byer og samfunn

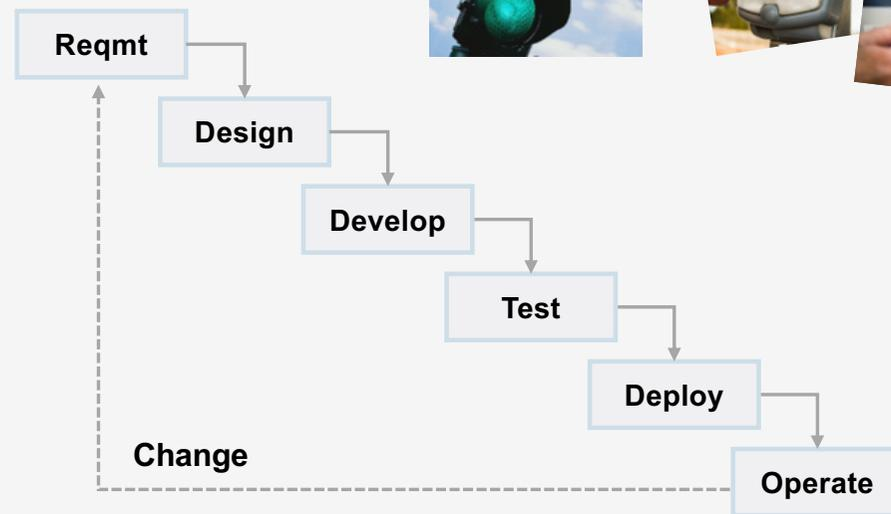
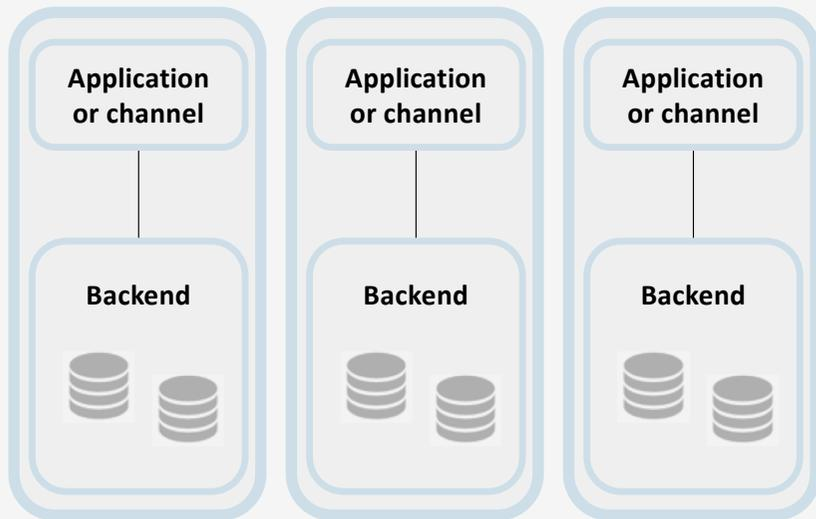
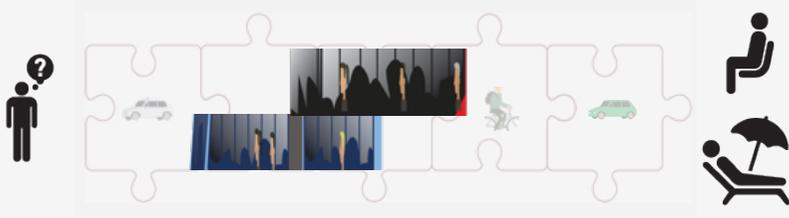

## New IT-platform - key characteristics

- EVERYONE and EVERYTHING is on-line
- Datacentric and event driven architecture
- Open source technologies
- Cloud-based
- Real-time processing



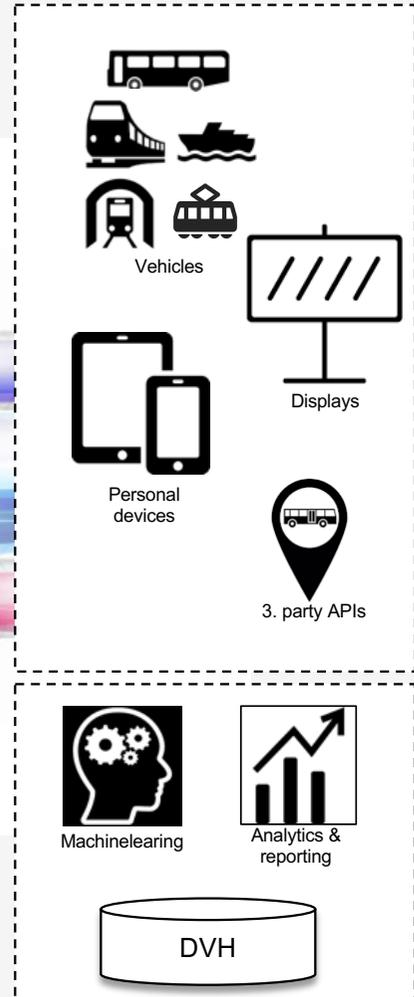

**Ruter#**

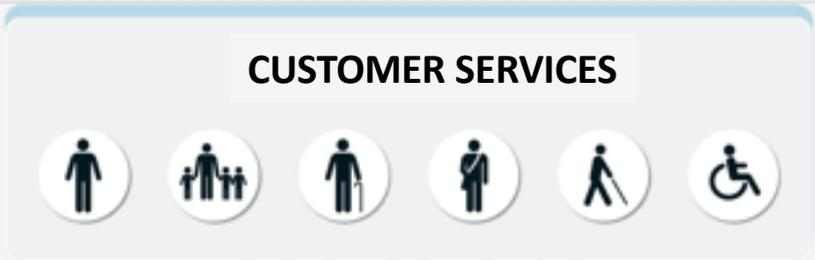
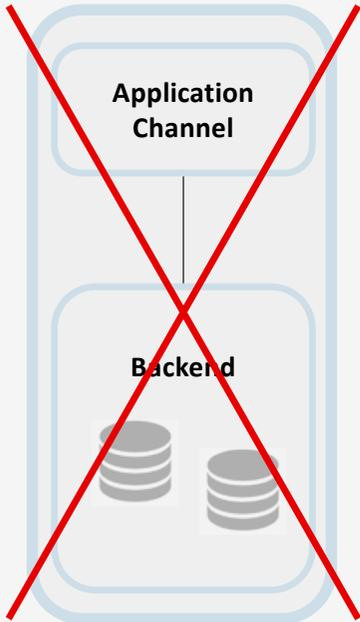

*Personal services*

*Public services*

«enablers»

*Scheduled services*

*On-demand services*

**Ruter#**



# On-board architecture

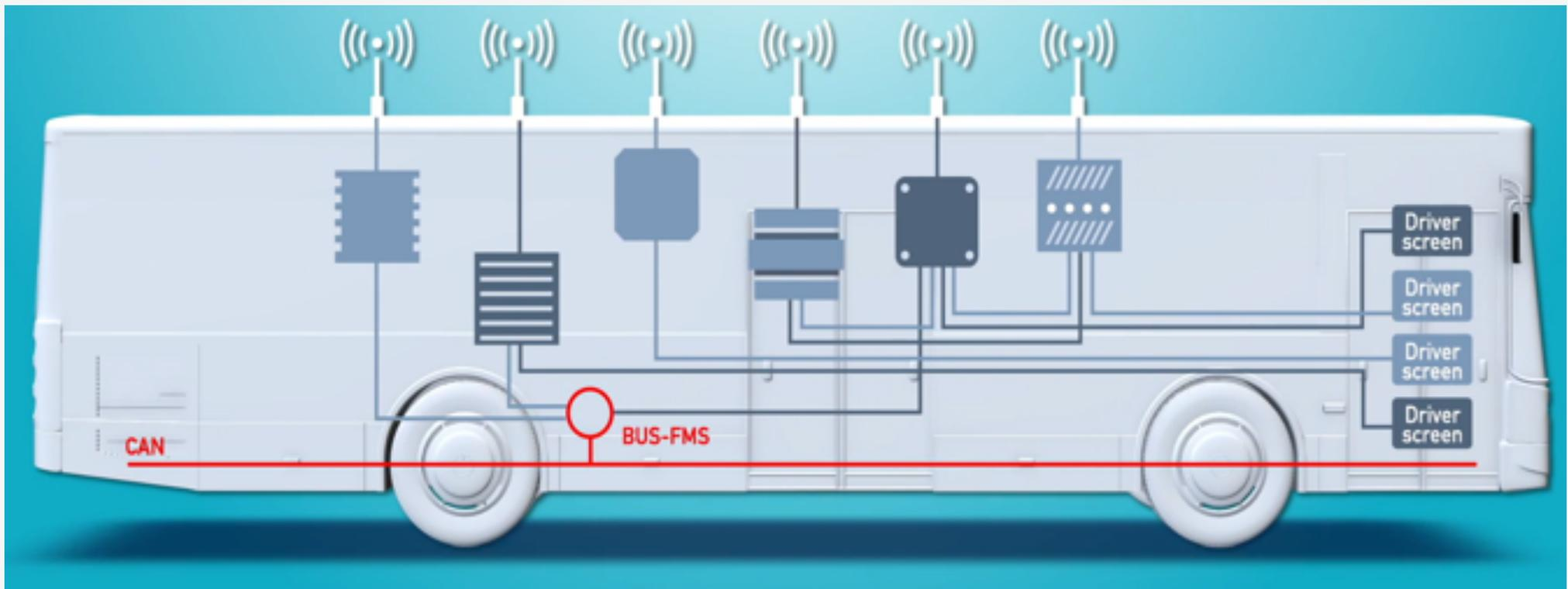
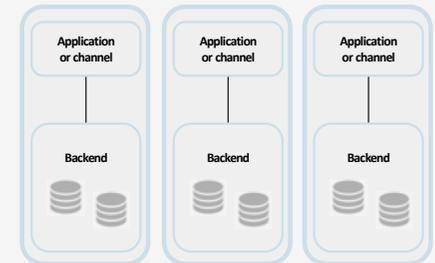

**Ruter#**

## New on-board architecture

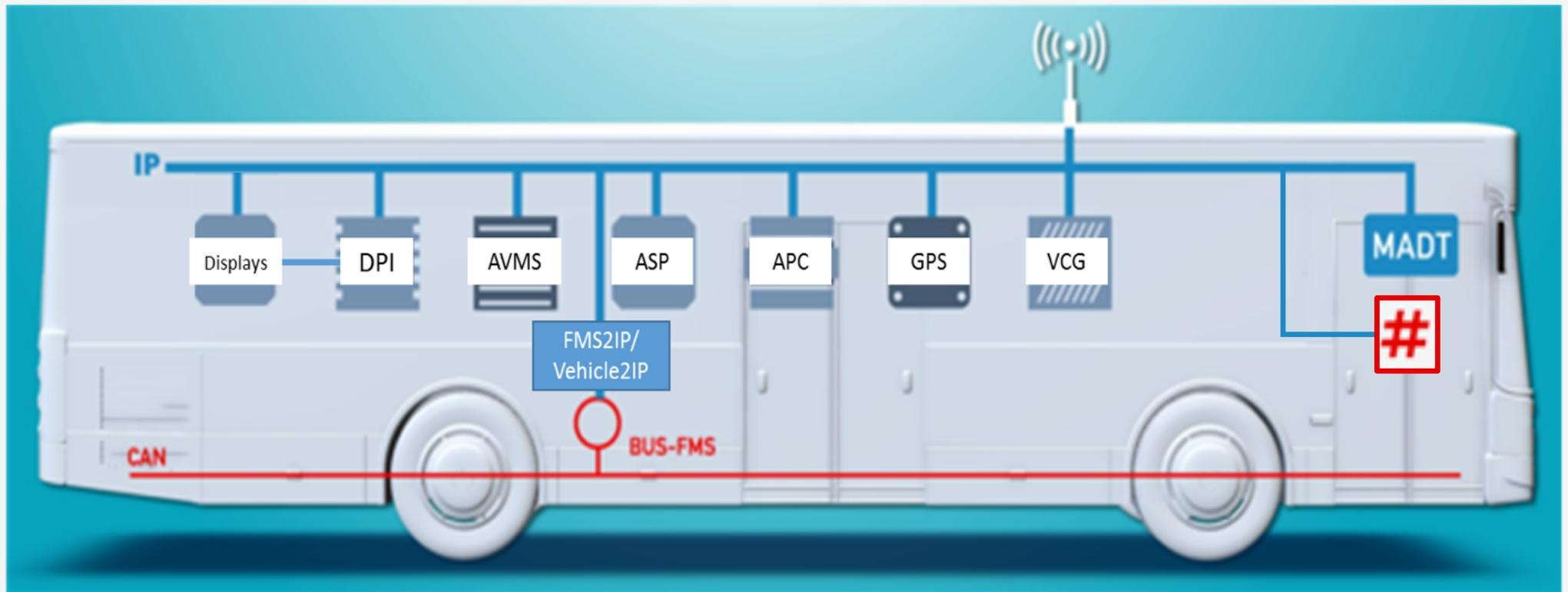

**Ruter#**



INFORMATION TECHNOLOGY  
for PUBLIC TRANSPORT

# ... August 2017 (41)



# ... August 2019 (109)



# 1 July 2019: 500 buses (of which 115 electric)

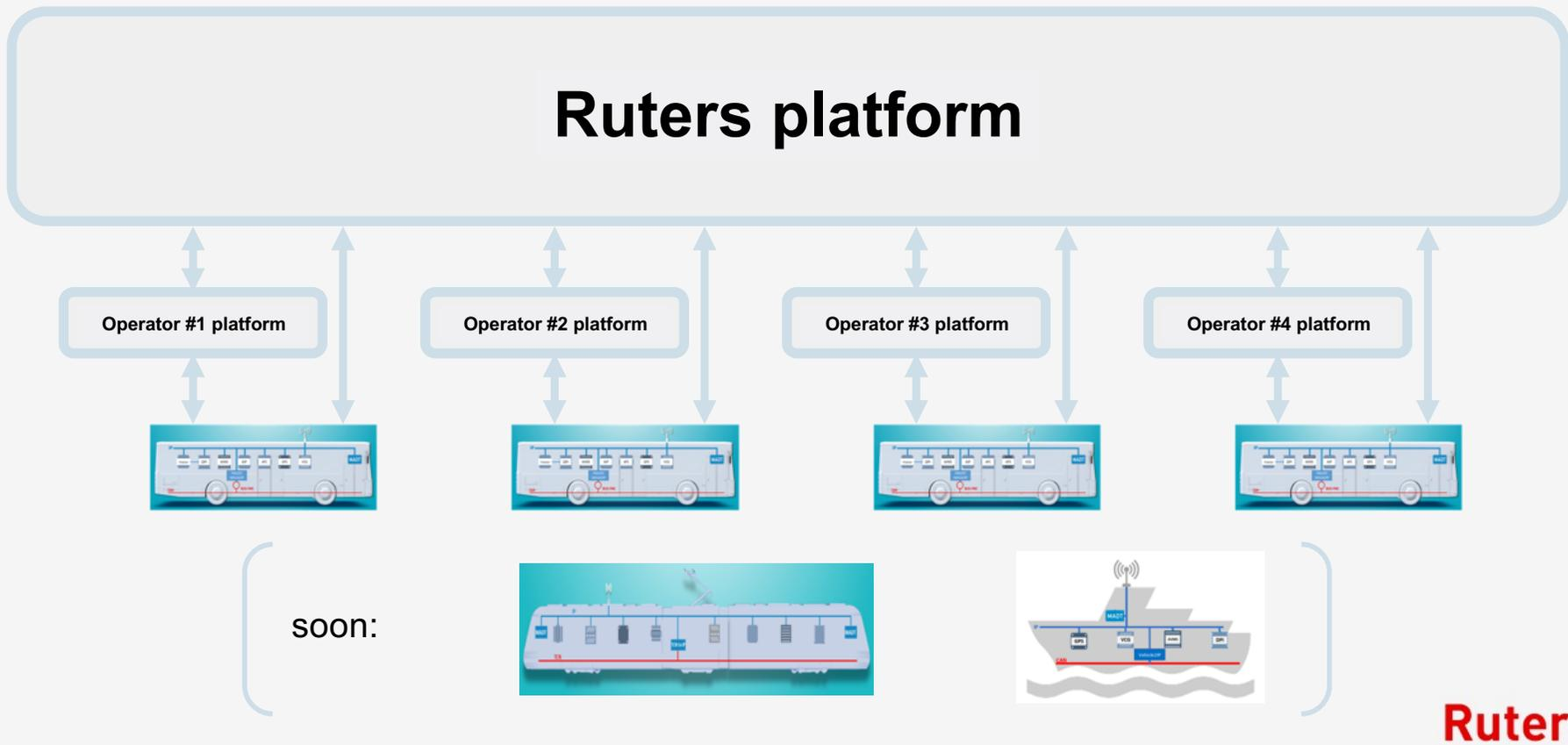



## Elbuss Electric bus

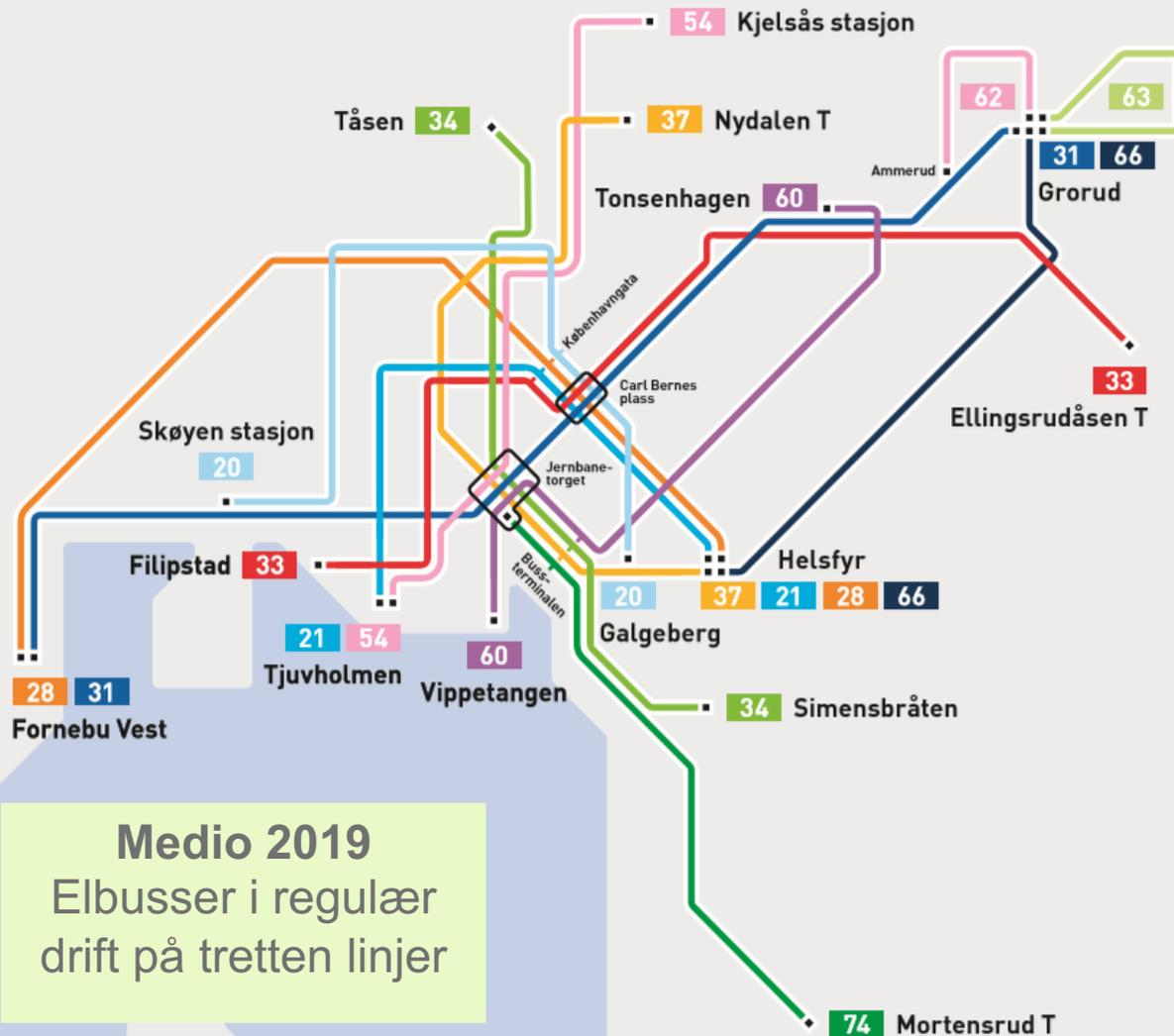

Medio 2019  
Elbusser i regulær  
drift på trettan linjer

Now the e-buses are  
'everywhere' in Oslo city  
center

Ruter#

..and some regional lines are fully electric



**Elbuss** Electric bus  
**Nedre Romerike**

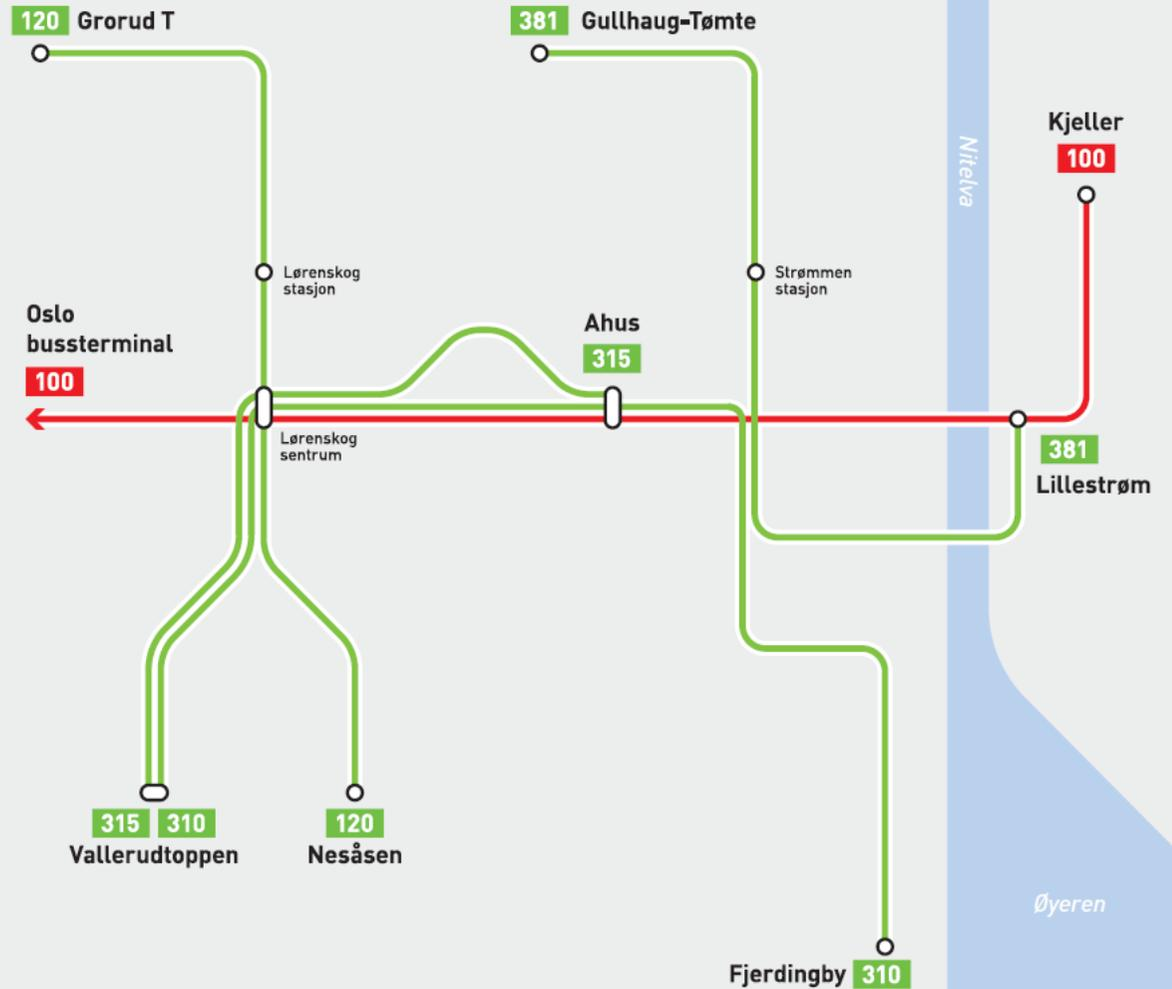

# Økende fokus



Personvern  
Informasjonssikkerhet

Etikk

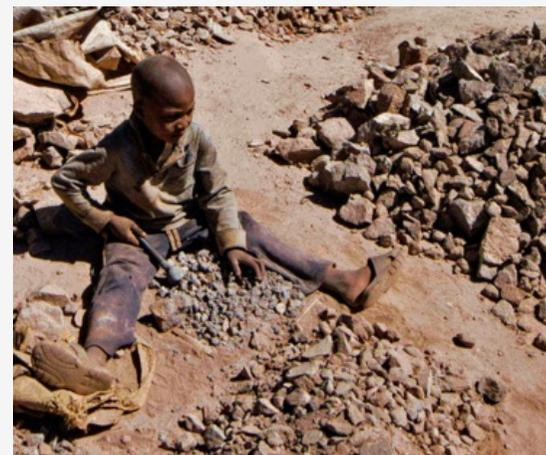

**Ruter#**



# Thank you for your attention

Terje Storhaug

VP & CIO

Head of *Digital Platforms & Systems*

[terje.storhaug@ruter.no](mailto:terje.storhaug@ruter.no)

+47 900 54 260

<https://www.linkedin.com/in/terjestorhaug>

